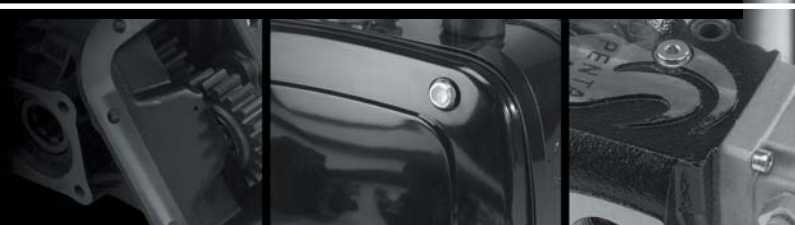

A photograph of several black Penta hydraulic cylinders of various sizes, with the brand name 'PENTA' visible on their bodies.

CYLINDERS | LIGHT DUTY

Dettagli Tecnici • Technical Data • Détail Techniques • Technischedatum • Detalles Tècnicos

A collage of three grayscale images showing detailed views of Penta hydraulic cylinder components, including a valve assembly, a cylinder head, and a mounting bracket.

TÜV SÜD TÜV SÜD TÜV SÜD TÜV SÜD TÜV SÜD TÜV SÜD TÜV SÜD TÜV SÜD TÜV SÜD TÜV SÜD TÜV SÜD TÜV SÜD TÜV SÜD TÜV SÜD TÜV SÜD

ZERTIFIKAT ◆ CERTIFICATE ◆ 認 證 證 書 ◆ CERTIFICADO ◆ CERTIFICAT



Italia

CERTIFICATO

Nr 50 100 2740 - Rev. 08

Si attesta che / This is to certify that

IL SISTEMA QUALITÀ DI
THE QUALITY SYSTEM OF

H.S. PENTA S.p.A.

SEDE LEGALE E OPERATIVA:
REGISTERED OFFICE AND OPERATIONAL SITE:

VIA PROVENTA 31
I-48018 FAENZA (RA)

È CONFORME AI REQUISITI DELLA NORMA
HAS BEEN FOUND TO COMPLY WITH THE REQUIREMENTS OF

UNI EN ISO 9001:2008

QUESTO CERTIFICATO È VALIDO PER IL SEGUENTE CAMPO DI APPLICAZIONE
THIS CERTIFICATE IS VALID FOR THE FOLLOWING SCOPE

**Progettazione, fabbricazione ed assistenza di cilindri oleodinamici
telescopici a singolo e doppio effetto; commercializzazione di dispositivi
idraulici per cilindri oleodinamici**
(IAF 18, 29)

**Design, manufacture and after-sale of telescopic hydraulic cylinders single
and double acting; retail of hydraulic devices for hydraulic cylinders**
(IAF 18, 29)



Per l'Organismo di Certificazione
For the Certification Body
TUV Italia S.r.l.

Validità / Validity

Dal / From: **2015-05-01**

Ai / To: **2018-04-30**

SGQ N° 049A SSI N° 005G PRD N° 081B
SGA N° 018D ITX N° 001L ISP N° 057E
SCR N° 009F PRS N° 077C LAB N° 0076

Membro degli Accordi di Mutuo Riconoscimento
EA, IAF e ILAC
Signatory of EA, IAF and ILAC Mutual Recognition
Agreements

Andrea Coscia
Direttore Divisione Management Service

Data emissione / Printing Date

2015-05-14

PRIMA CERTIFICAZIONE / FIRST CERTIFICATION: 2003-05-20

"LA VALIDITÀ DEL PRESENTE CERTIFICATO È SUBORDINATA A SORVEGLIANZA PERIODICA A 12 MESI E AL RIESAME COMPLETO DEL SISTEMA DI GESTIONE AZIENDALE CON PERIODICITÀ TRIENNALE"

"THE VALIDITY OF THE PRESENT CERTIFICATE DEPENDS ON THE ANNUAL SURVEILLANCE EVERY 12 MONTHS AND ON THE COMPLETE REVIEW OF COMPANY'S MANAGEMENT SYSTEM AFTER THREE-YEARS"



Index



LIGHT DUTY

2 L 174

3 L 160

4 L 140

5 L 120

6 L 105

7 L 90

8 L 75

9 Notes

10-11 Selection Charts

12 Assembly

Endpaper Warnings - Warranty

L 174

EFFECTIVE DIAMETER [mm] 174 • 154 • 135 • 120 • 105 • 90 • 75 • 60

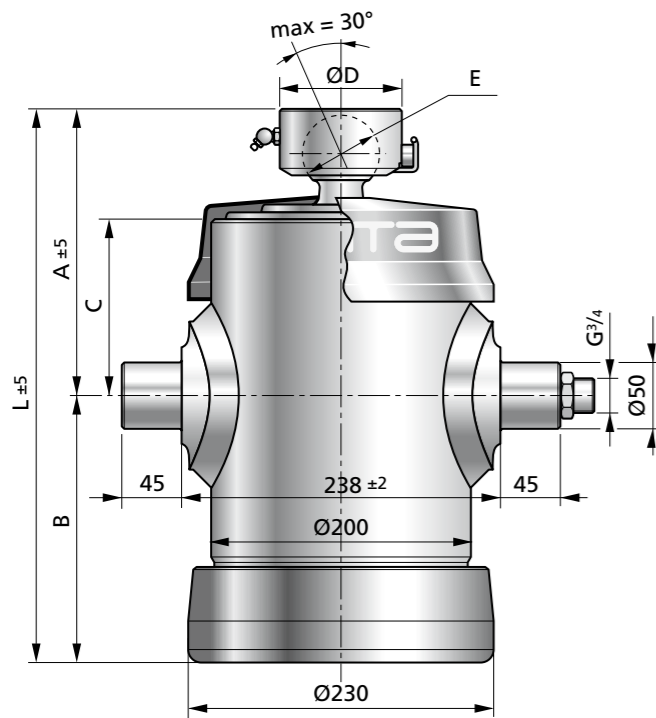

ACCESSORIES

CYLINDER SUPPORT • PAIR A70050001

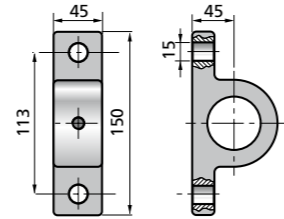

CRADLE SUPPORT • PAIR A60050001

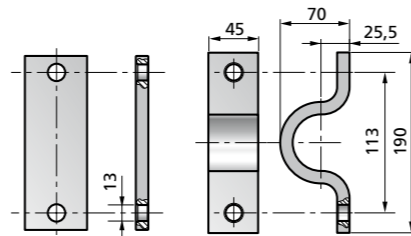

CRADLE A50200001

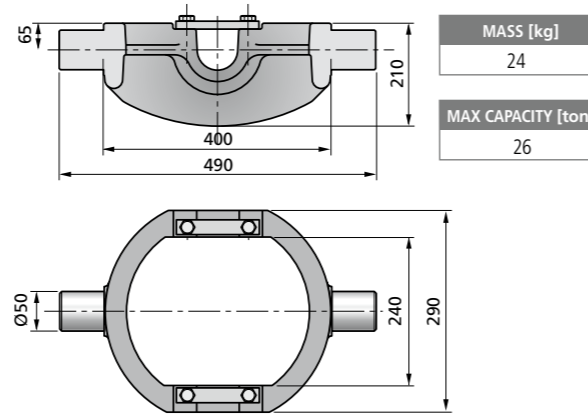

L 160

EFFECTIVE DIAMETER [mm] 160 • 140 • 120 • 105 • 90 • 75 • 60

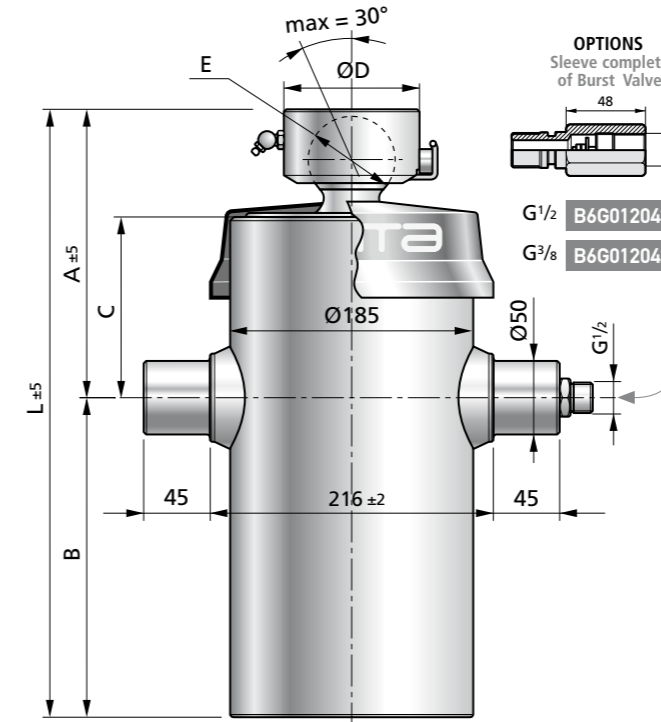

OPTION with ROD EYE - PINS

OPTION with ROD EYE - LOWER PINS

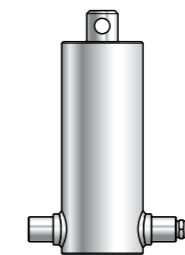
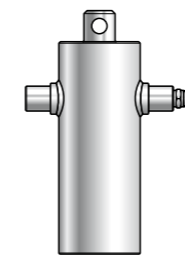

ACCESSORIES

CYLINDER SUPPORT • PAIR A70050001

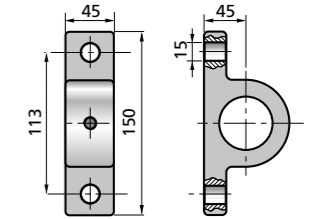

CRADLE SUPPORT • PAIR A60050001

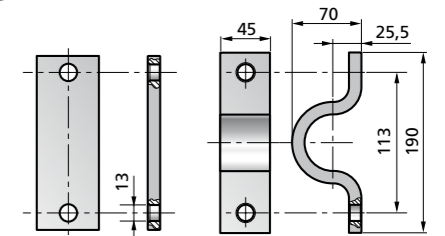

CRADLE A50300001

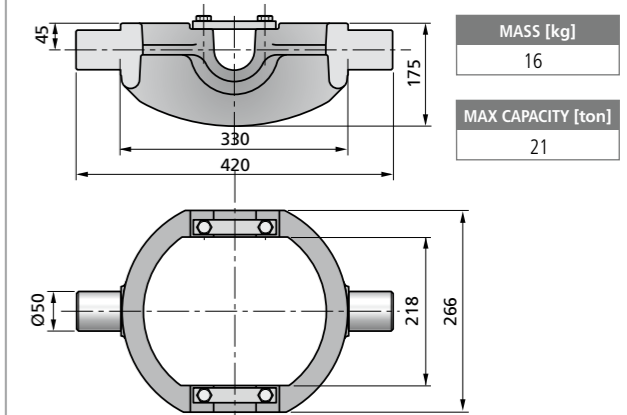

L 174 TECHNICAL DATA

MODEL	CODE	EXTENSIONS N.	POWER STROKE [mm]	MASS [kg]	WORKING VOLUME [dm ³]	MAX. WORKING PRESSURE [bar]	TIPPING CAPACITY [ton]	L	A	B	C	D	E
BL300 1796 174 8	3103001748001	8	1796	78	20,1	180	14-24	417	216	201	133	92	58
BL300 1569 174 7	3103001747001	7	1569	81	19,5	180	17-28	417	216	201	133	92	58
BL300 1345 174 6	3103001746001	6	1345	74	18,5	180	18-30	417	216	201	133	92	58

L 160 TECHNICAL DATA

MODEL	CODE	EXTENSIONS N.	POWER STROKE [mm]	MASS [kg]	WORKING VOLUME [dm ³]	MAX. WORKING PRESSURE [bar]	TIPPING CAPACITY [ton]	L	A	B	C	D	E
BL400 2255 160 7	3104001607001	7	2255	76	22,6	180	12-21	517	246	271	174	92	58
BL400 1935 160 6	3104001606001	6	1935	77	21,7	180	15-25	517	246	271	174	92	58
BL400 1615 160 5	3104001605001	5	1615	68	20,2	180	17-29	517	246	271	174	92	58
BL400 1300 160 4	3104001604001	4	1300	65	18,2	180	17-29	517	246	271	174	92	58
BL300 1600 160 7	3103001607001	7	1600	61	16,1	180	12-21	423	219	204	147	92	58
BL300 1370 160 6	3103001606001	6	1370	61	15,4	180	15-25	423	219	204	147	92	58
BL300 1145 160 5	3103001605001	5	1145	55	14,4	180	17-29	423	219	204	147	92	58

L 140

EFFECTIVE DIAMETER [mm] 140 • 120 • 105 • 90 • 75 • 60

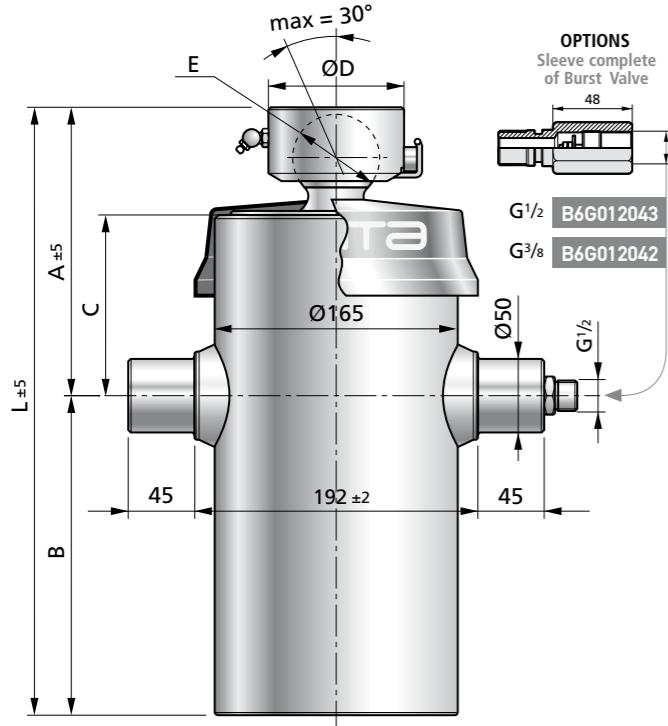

OPTION with RODEYE - PINS

OPTION with ROD EYE - LOWER PINS

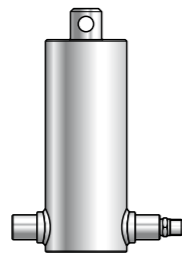
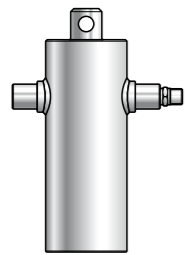

ACCESSORIES

CYLINDER SUPPORT • PAIR A70050001

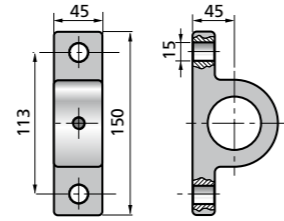

CRADLE SUPPORT • PAIR A60050001

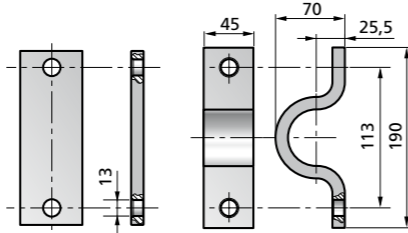

CRADLE A50400001

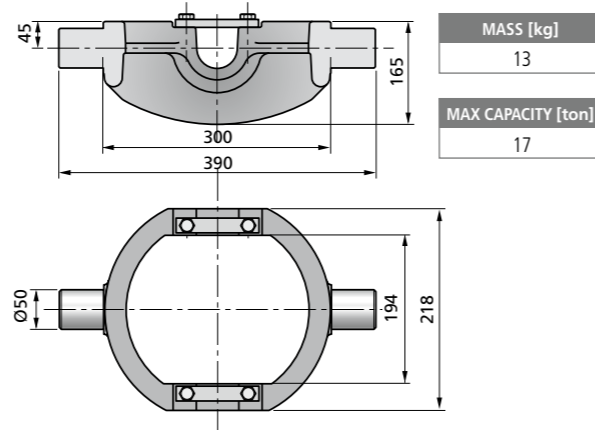

L 120

EFFECTIVE DIAMETER [mm] 120 • 105 • 90 • 75 • 60 • 45

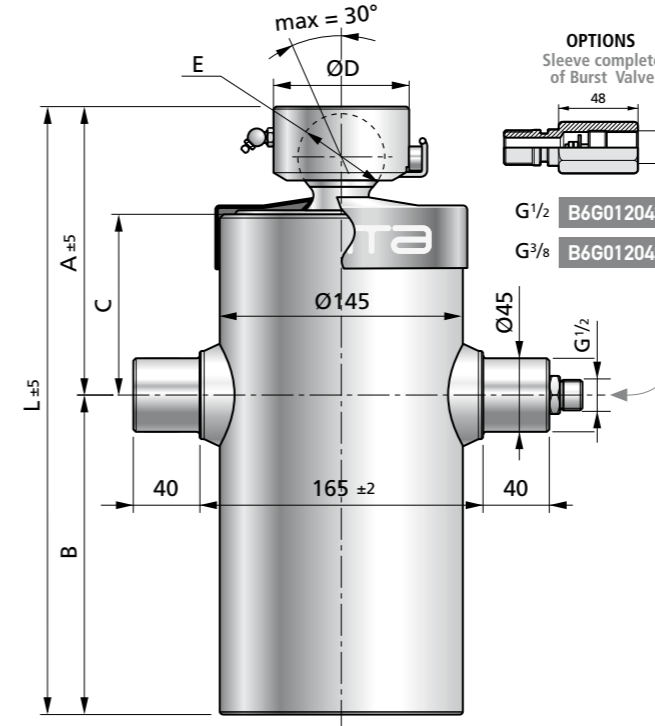

OPTION with RODEYE - PINS

OPTION with ROD EYE - LOWER PINS

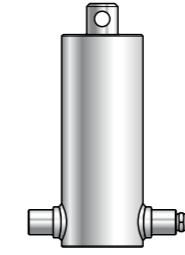
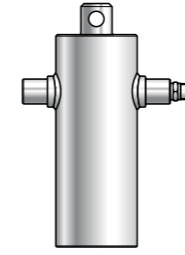

ACCESSORIES

CYLINDER SUPPORT • PAIR A70045001

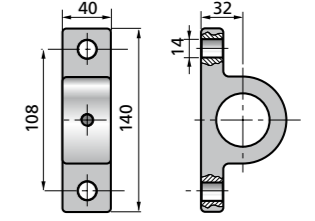

CRADLE SUPPORT • PAIR A60045001

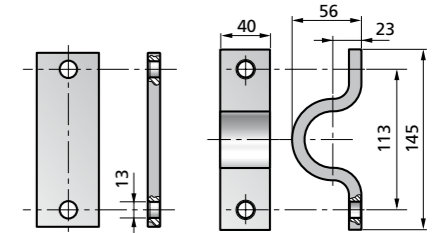

CRADLE A5L080001

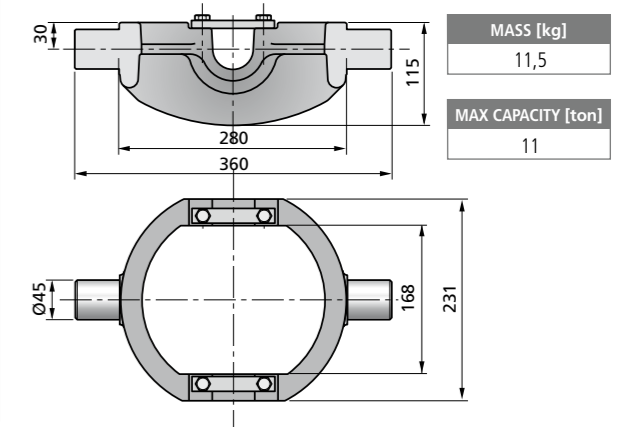

L 140 TECHNICAL DATA

MODEL	CODE	EXTENSIONS N.	POWER STROKE [mm]	MASS [kg]	WORKING VOLUME [dm ³]	MAX. WORKING PRESSURE [bar]	TIPPING CAPACITY [ton]	L	A	B	C	D	E
BL400 1940 140 6	3104001406001	6	1940	61	16	180	11-18	510	234	276	162	92	58
BL400 1615 140 5	3104001405001	5	1615	63	15,1	180	13-22	510	234	276	162	92	58
BL400 1295 140 4	3104001404001	4	1295	53	13,7	180	15-25	510	234	276	162	92	58
BL300 1375 140 6	3103001406001	6	1375	49	11,4	180	11-18	416	242	174	170	92	58
BL300 1145 140 5	3103001405001	5	1145	50	10,8	180	13-22	416	242	174	170	92	58
BL300 920 140 4	3103001404001	4	920	43	9,8	180	15-25	416	242	174	170	92	58
BL270 1190 140 6	3102701406001	6	1190	45	9,9	180	11-18	385	204	181	132	92	58
BL270 990 140 5	3102701405001	5	990	46	9,3	180	13-22	385	204	181	132	92	58
BL270 795 140 4	3102701404001	4	795	40	8,5	180	15-25	385	204	181	132	92	58
* RS195 980 140 7	3501951407001	7	980	35	7,2	180	9-15	281	165	116	108	120	43

* With squared Cap

L 120 TECHNICAL DATA

MODEL	CODE	EXTENSIONS N.	POWER STROKE [mm]	MASS [kg]	WORKING VOLUME [dm ³]	MAX. WORKING PRESSURE [bar]	TIPPING CAPACITY [ton]	L	A	B	C	D	E
BL445 2250 120 6	3104451206001	6	2250	50	13,2	200	7-14	541	143	398	88	74	43
BL445 1870 120 5	3104451205001	5	1870	55	12,6	200	9-17	558	160	398	88	92	58
BL445 1500 120 4	3104451204001	4	1500	55	11,6	200	11-21	558	160	398	88	92	58
BL410 2055 120 6	3104101206001	6	2055	47	12,1	200	7-14	508	215	293	160	74	43
BL410 1705 120 5	3104101205001	5	1705	50	11,5	200	9-17	525	232	293	160	92	58
BL410 1365 120 4	3104101204001	4	1365	51	10,6	200	11-21	525	232	293	160	92	58
BL370 895 120 3	3103701203001	3	895	38	7,9	200	13-24	480	197	283	125	92	58
BL360 1725 120 6	3103601206001	6	1725	42	10,2	200	7-14	453	180	273	125	74	43
BL360 1430 120 5	3103601205001	5	1430	44	9,7	200	9-17	470	197	273	125	92	58
BL360 1145 120 4	3103601204001	4	1145	46	8,8	200	11-21	470	197	273	125	92	58
BL305 1410 120 6	3103051206001	6	1410	36	8,3	200	7-14	401	180	221	125	74	43
BL305 1170 120 5	3103051205001	5	1170	39	7,9	200	9-17	418	197	221	125	92	58
BL275 1240 120 6	3102751206001	6	1240	37	7,3	200	7-14	372	180	192	125	74	43
BL275 1025 120 5	3102751205001	5	1025	35	7	200	9-17	389	197	192	125	92	58

L 105

EFFECTIVE DIAMETER [mm] 105 • 90 • 75 • 60 • 45 • 30

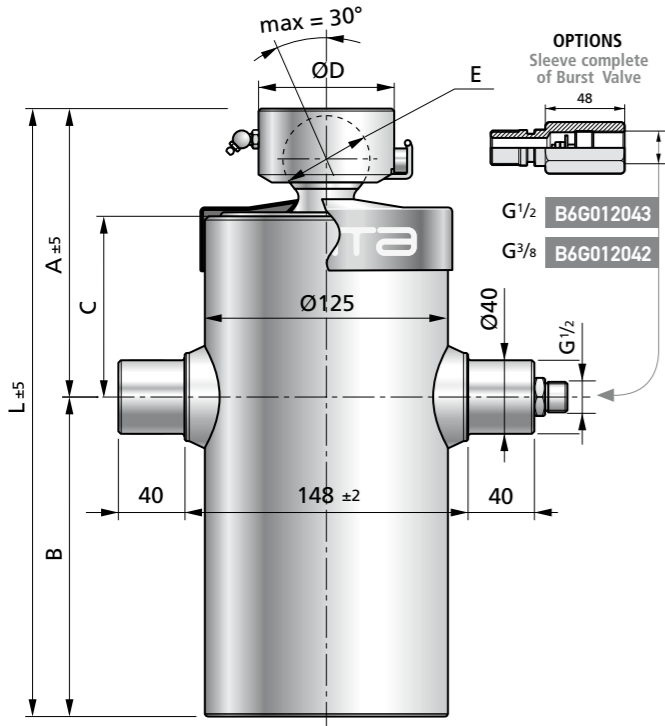

OPTION with ROD EYE - PINS

OPTION with ROD EYE - LOWER PINS

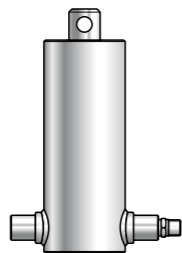
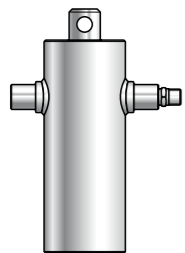

ACCESSORIES

CYLINDER SUPPORT • PAIR A70040001

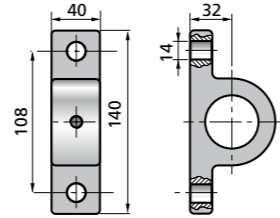

CRADLE SUPPORT • PAIR A60040001

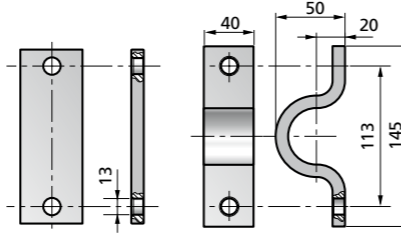

CRADLE A5L060001

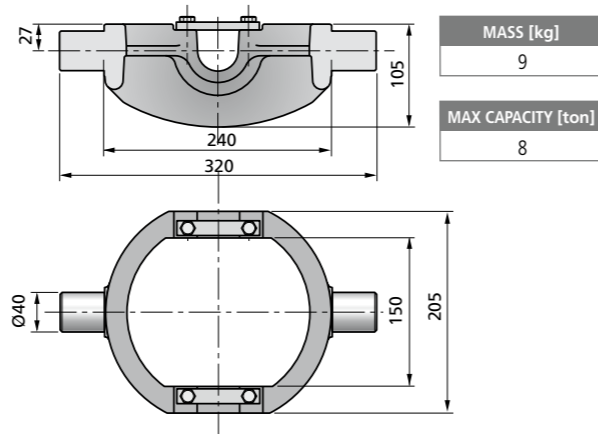

L 90

EFFECTIVE DIAMETER [mm] 90 • 75 • 60 • 45 • 30

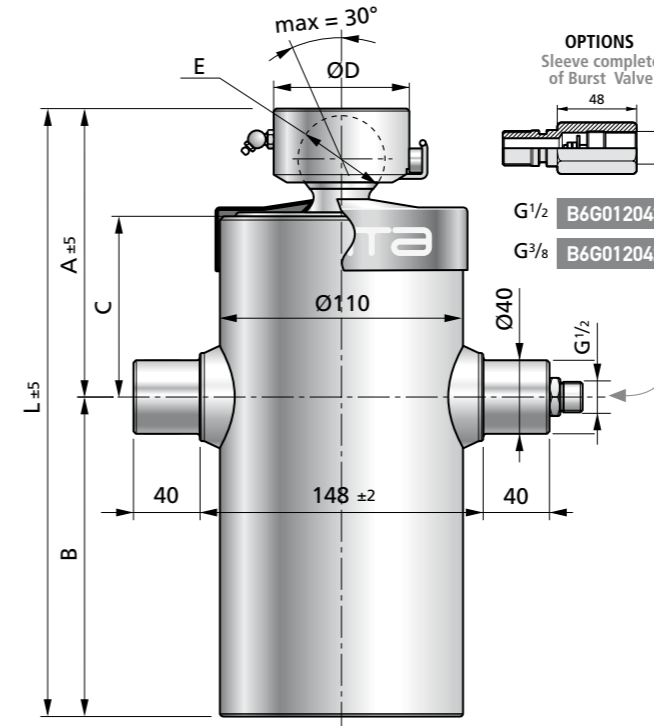

OPTION with ROD EYE - PINS

OPTION with ROD EYE - LOWER PINS

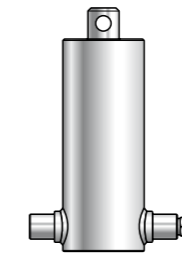
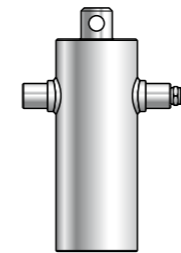

ACCESSORIES

CYLINDER SUPPORT • PAIR A70040001

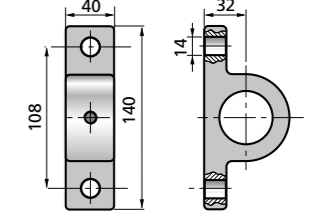

CRADLE SUPPORT • PAIR A60040001

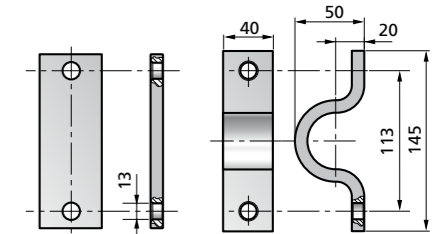

CRADLE A5L060001

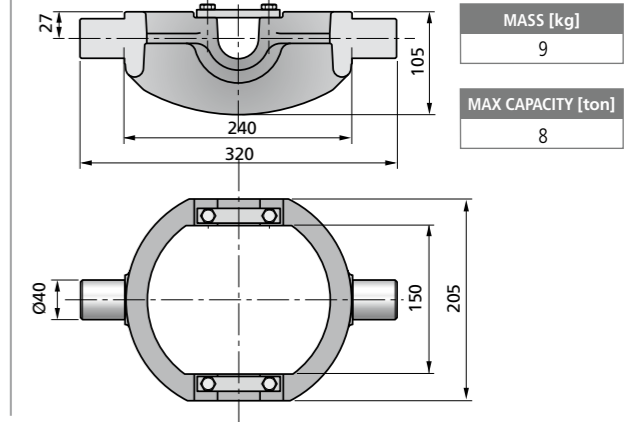

L 105 TECHNICAL DATA

MODEL	CODE	EXTENSIONS N.	POWER STROKE [mm]	MASS [kg]	WORKING VOLUME [dm ³]	MAX. WORKING PRESSURE [bar]	TIPPING CAPACITY [ton]	L	A	B	C	D	E
BL445 1875 105 5	3104451055001	5	1875	38	8,9	200	6-12	532	140	392	85	74	43
BL445 1495 105 4	3104451054001	4	1495	40	8,3	200	8-15	549	157	392	85	92	58
BL360 1435 105 5	3103601055001	5	1435	30	6,8	200	6-12	444	150	294	95	74	43
BL360 1140 105 4	3103601054001	4	1140	33	6,4	200	8-15	461	167	294	95	92	58
BL360 855 105 3	3103601053010	3	855	35	5,6	200	10-18	461	167	294	95	92	58
BL320 1240 105 5	3103201055001	5	1240	28	5,9	200	6-12	405	150	255	95	74	43
BL320 985 105 4	3103201054001	4	985	27	5,5	200	8-15	405	150	255	95	74	43
BL320 985 105 4	3103201054003	4	985	29	5,4	200	8-15	422	167	255	95	92	58
BL275 1030 105 5	3102751055001	5	1030	24	4,9	200	6-12	363	150	213	95	74	43
BL275 820 105 4	3102751054001	4	820	22	4,6	200	8-15	363	150	213	95	74	43
BL265 1175 105 6	3102651056001	6	1175	22	4,7	200	5-9	351	151	200	95	74	43
BL235 1005 105 6	3102351056001	6	1005	21	4,1	200	5-9	323	151	172	95	74	43

L 90 TECHNICAL DATA

MODEL	CODE	EXTENSIONS N.	POWER STROKE [mm]	MASS [kg]	WORKING VOLUME [dm ³]	MAX. WORKING PRESSURE [bar]	TIPPING CAPACITY [ton]	L	A	B	C	D	E
BL475 1200 90 3	3104750903001	3	1200	35	5,4	220	5-14	578	180	398	108	92	58
BL360 1140 90 4	3103600904001	4	1140	25	4,3	220	5-11	445	156	289	100	74	43
BL360 850 90 3	3103600903001	3	850	26	3,8	220	5-14	445	156	289	100	74	43
BL320 1250 90 5	3103200905001	5	1250	25	4	220	4-8	405	155	250	100	74	43
BL320 985 90 4	3103200904001	4	985	23	3,7	220	5-11	405	155	250	100	74	43
BL275 820 90 4	3102750904001	4	820	20	3,1	220	5-11	363	155	208	100	74	43
BL245 680 90 4	3102450904001	4	680	19	2,5	220	5-11	328	152	176	97	74	43

Selection Charts

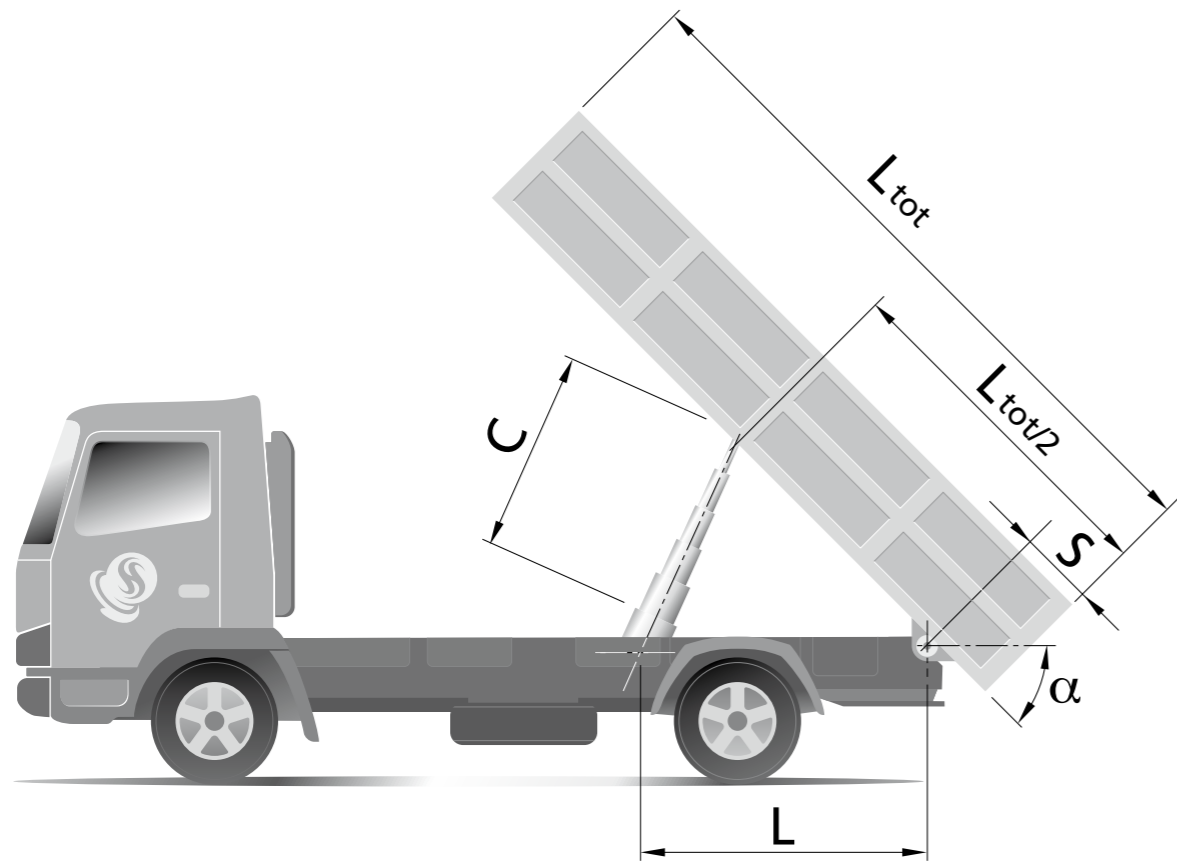

STROKE						
L [mm]	BODY TILTING α [°]					
	40	45	48	50	55	60
500	342	383	407	423	462	500
750	513	574	610	634	693	750
1000	684	765	813	845	923	1000
1100	752	842	895	930	1016	1100
1200	821	918	976	1014	1108	1200
1300	889	995	1058	1099	1201	1300
1400	958	1072	1139	1183	1293	1400
1500	1026	1148	1220	1268	1385	1500
1600	1094	1225	1302	1352	1478	1600
1700	1163	1301	1383	1437	1570	1700
1800	1231	1378	1464	1521	1662	1800
1900	1300	1454	1546	1606	1755	1900
2000	1368	1531	1627	1690	1847	2000
2150	1471	1646	1749	1817	1986	2150
2300	1573	1760	1871	1944	2124	2300
2450	1676	1875	1993	2071	2263	2450
2600	1779	1990	2115	2198	2401	2600
2750	1881	2105	2237	2324	2540	2750
3000	2052	2296	2440	2536	2770	3000
3200	2189	2449	2603	2705	2955	3200

C POWER STROKE
[mm]

$$C_{[mm]} = 2L_{[mm]} \sin\left(\frac{\alpha_{[rad]}}{2}\right) \Rightarrow$$

$$\Rightarrow C_{[mm]} \cong \frac{3,1416}{180} \cdot \alpha_{[°]} \cdot L_{[mm]} \cdot \left(1 - \frac{9,8696}{777600} \alpha_{[°]}^2\right)$$

• The stroke is identified by crossing the pivot length (L) with the requested tipping angle (°).

EXTENSION Ø [mm]	PRESSIONE PRESSURE [bar]									THRUST [kN]
	50	75	100	125	150	175	200	220	240	
30	4	5	7	9	11	12	14	16	17	
45	8	12	16	20	24	28	32	35	38	
60	14	21	28	35	42	49	57	62	68	
75	22	33	44	55	66	77	88	97	106	
90	32	48	64	80	95	111	127	140	153	
105	43	65	87	108	130	152	173	190	208	
120	57	85	113	141	170	198	226	249	271	
135	72	107	143	179	215	250	286	315	343	
140	77	115	154	192	231	269	308	338	369	
154	15	140	186	233	279	326	372	410	447	
160	100	151	201	251	301	352	402	442	482	
174	119	178	238	297	356	416	475	523	570	

$$S_{[kN]} = \frac{\pi}{4} d_{[mm]}^2 \frac{p_{[bar]}}{10000} \Rightarrow$$

$$\Rightarrow S_{[kN]} \cong \frac{0,785}{10000} d_{[mm]}^2 p_{[bar]}$$

• The thrust is a force generated by oil under pressure, which lifts the stage of the cylinder. "D" is the diameter of the stage.

TYPE	TOTAL MASS [ton]							EXTENSION N.	
	25÷30	20÷25	15÷20	13÷15	11÷13	9÷11	7÷9		4÷7
L174	6	7	8						
L160	5	6	7						
L140		4	5	6					
L120			3	4	5	6			
L105					3	4	5	6	
L90						3	4	5	
L75							2	3	

• Depending on the total tipping weight, the chart identifies the most suitable model and number of stages available.

Assembly

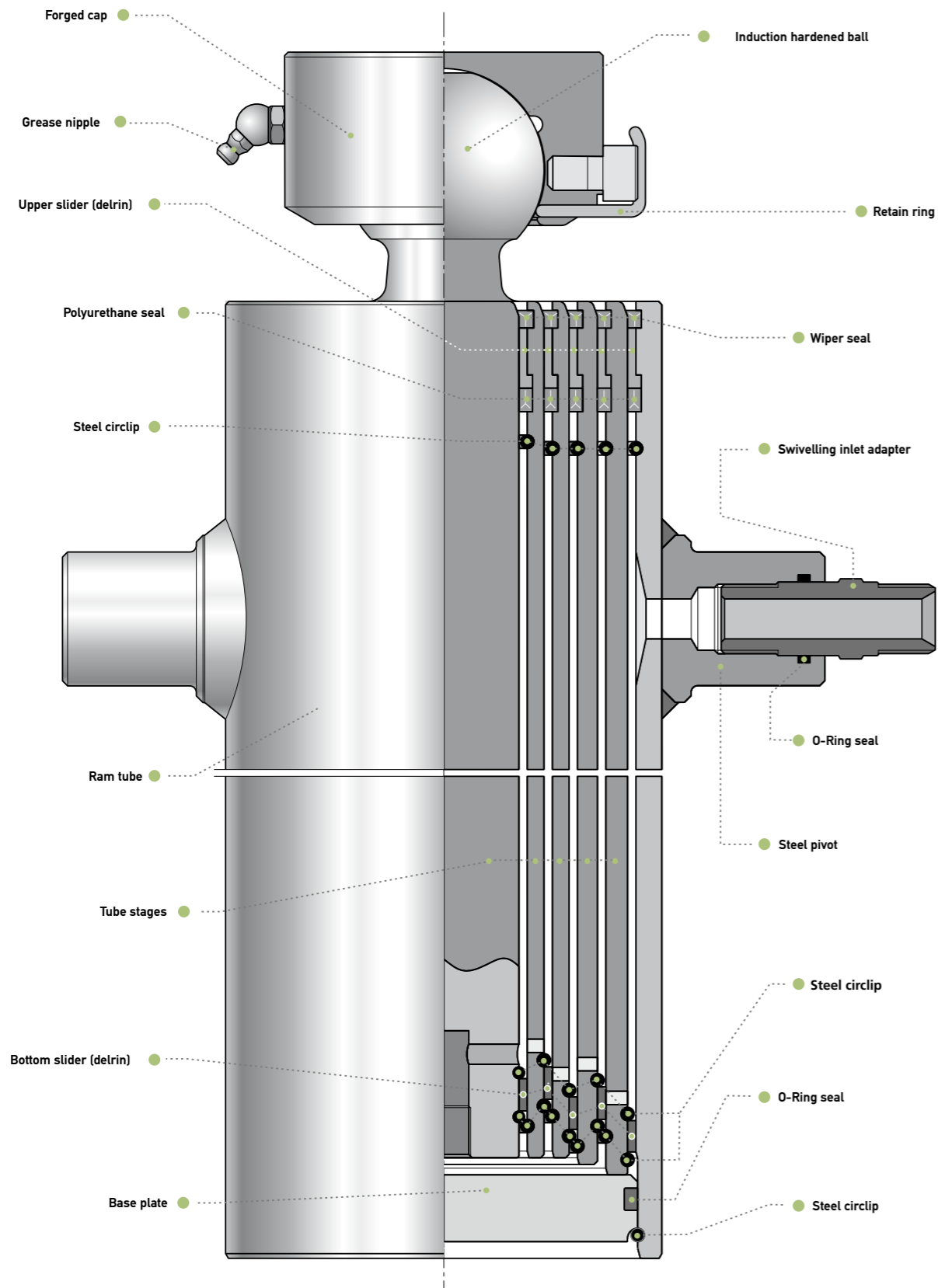

Warnings

USER RESPONSABILITY

Incorrect selection or incorrect use of the here described component and its related items may cause death, personal injury and property damage. Documents and information supplied by H.S.PENTA are intended for further investigations by users with technical knowledge. The user, as manufacturer of the completed machinery which will incorporate the components supplied by H.S.PENTA, is the solely responsible for the final selection of the products. The user must carry out necessary research and tests on components to determine whether, by its design and construction, all performance, endurance, maintenance, safety and warning requirements are met. The user must assure the compliance of the completed machinery with all appropriate laws, directives, norms, industry standards. To the extent that H.S.PENTA provide component or system options based upon data or specifications provided by the user, the user is responsible for determining that such data and specifications are suitable and sufficient for all applications and reasonably foreseeable uses of the components or systems.

1. Conditions of use

The hydraulic cylinder is a component that is intended to be incorporated into machinery which must meet the requirements of the applicable directives and standards. If here reported advices are not met and if the machinery that incorporates the cylinder is non-compliant with directives, the guarantee will not be applicable and H.S.PENTA will refuse all responsibility for every consequence of the use of the cylinder. The hydraulic cylinder for tipper is a linear actuator therefore it is designed to provide a pushing force acting along the cylinder axis and must not be subject to side and/or pulling loads. The hydraulic cylinder is not a structural member and must not be used as a stabilizer or to retain the moving body, it cannot prevent the dump body or trailer from rollover or lateral tilt. Rollover or lateral tilt are the causes that can bend, swell, strain or break off the cylinder causing the sudden fall of the body with serious risk of damage, injury or death. The hydraulic cylinder cannot in any way be the reason of rollover, but it can only stand the consequences of it. The hydraulic cylinder, once installed, must be free by every side load or bending load. Misalignment between brackets and impediment of free rotation can cause the failure of the hydraulic cylinder (i.e.: damages on cylinder stages, oil leaking, out of sequence, etc.). The manufacturer of complete machinery must prevent all conditions that can induce improper loads on the cylinders. For example in case of a tipper vehicle: tires and suspensions must be in optimal working conditions, the cylinder must not be opened in case of soft and/or uneven ground or, in case of semi-trailer tipper, if trailer and prime-mover are misaligned. In tipping equipment working outside the cylinder must not be opened in case of strong wind. Generally, the cylinder must not be opened in all conditions which can affect the stability of the tipping equipment.

Guarantee

1. Guarantee conditions

- 1.1 H.S.PENTA S.P.A. (hereinafter referred to as the "Company") guarantees the satisfactory operation of its hydraulic components, hydraulic cylinders, and respective accessories (hereinafter jointly referred to as the "Products") and the absence of flaws and defects in the same within the limits specified in these General Guarantee Conditions.
- 1.2 This guarantee of satisfactory operation has a validity of two (2) years from the date of sale of the Products.
- 1.3 The Company guarantees the conformity of the Products exclusively to Italian and European Community standards.

2. Guarantee coverage

- 2.1 Without prejudice to the content of the following Article 2.2 regarding hidden defects, the Products will be considered as having been accepted by the purchaser whenever within 5 days from delivery such latter has not provided the Company with written notice of the presence of flaws and/or defects.
- 2.2 Upon pain of relinquishing rights to coverage under the guarantee, the purchaser must provide the Company with written notice of the defect in conformity and/or flaw in the Product or part of the same, specifying the nature of the same in detail within 8 days of the date in which the purchaser has observed such defect in conformity and/or flaw.
- 2.3 The defective Products reported in such notice as per the sense and effect of Article 2.2 above must be conserved by the purchaser for the purpose of examination by the Company. Following written request from the Company, the purchaser must send the defective Product(s) carriage paid to the latter or the party indicated by the same; whenever after the Company's examination, the Product is declared defective and as such is covered by these General Guarantee Conditions, the Company will reimburse the purchaser for the costs of shipping, while remaining expressly specified that such shipping costs must be within the average reference costs. The purchaser relinquishes the right to coverage under guarantee whenever he does not permit every reasonable inspection of the Product requested by the Company or whenever after receiving written request from the Company for the return of the Product he fails to do so within 30 days of receiving such request.
- 2.4 Following transmission of due notice by the purchaser performed as per the sense and effect of previous Article 2.2, after ascertaining the existence of the defect or flaw, the Company can take any of the following courses of action at its own discretion:
 - (a) provide the purchaser with Products in replacement of those defective free-of-charge;
 - (b) repair the Products directly or through third parties at its own expense; or
 - (c) reimburse the price paid by the purchaser for the Products ascertained defective.
 It is hereby agreed that any Products supplied in replacement of those proven defective must be shipped "ex-works" and that the defective Products returned to the Company will remain the property of such latter.
- 2.5 With the exception of those mentioned in Article 2.4 above, the costs and expenses incurred by the replacement or repair of the defective Products must be borne by the purchaser.

- For mere purposes of example without excluding others, the purchaser must bear the costs for:
- (a) consumptions caused by the removal of the defective Products from the machinery in which they were installed and the subsequent re-installation of the same;
 - (b) the transport of materials and/or equipment;
 - (c) lubricants and/or expendable materials necessary for the replacement or repair of the defective Products;

1.1 Ordinary operations

The normal application of telescopic cylinder is to lift up tipping bodies, loaded with different materials, and consequently discharge this material whilst the cylinder is extended all along its stroke, considering the specified limits of the cylinder. Unless otherwise stated, the hydraulic cylinders are single acting and the force generated by the weight of the moving body will close the cylinder. If the tipping equipment is fitted on a vehicle, the body builder must consider that the hydraulic cylinder are not suitable to act and/or to be loaded when the vehicle is moving. The tipping body of the equipment must not lie on the cylinder when the vehicle is moving.

1.2 Selection of the cylinder

The body weight plus the max payload are the max tipping weight that can be raised by the cylinder. This value, called "tipping weight", is a rough indication of the tipping power of the cylinder and must be used as a first criteria for the selection of the cylinder. The real tipping mass can only be calculated by the design engineer of the completed machinery, and must take into account the geometry of the dump body, operating conditions, all reasonably foreseeable uses, the maximum pressure and other possibly limits stated for the cylinder. The manufacturer of the tipping equipment must consider all reasonably foreseeable uses and all possibly dynamic loads produced by the operations. In particular the manufacturer must assure sufficient safety margin on critical buckling load of the cylinder (if this value is not stated, the manufacturer can ask it to H.S.PENTA). For example, in case of sticky loads, it must be avoided that the user can roughly operate: the dynamic loads produce great peaks of pressure that can damage the cylinder and it is possible to reach the critical buckling load of the cylinder causing the collapse of the hydraulic cylinder and the sudden fall of the moving body with severe risks of death, personal injury and property damage. Furthermore, the manufacturer must consider possible geometric limits of the hinges of the cylinder and its accessory (if not stated, the manufacturer can ask to H.S.PENTA), i.e.: the maximum allowed angle between the top cap and the spherical ball on piston rod is 30°. Unless otherwise stated, the hydraulic cylinder are single acting and a minimum load of 250 kg must be assured to close the cylinder.

1.3 Selection of the cylinder

The stages of any cylinder can be exposed to corrosion when used in very humid or aggressive environment, and should never remain fully extended for a period exceeding the tipping time. H.S.PENTA guarantee does not cover flou or defect regarding the corrosion of the parts of the product coated or not coated. H.S.PENTA telescopic cylinders can be used under environment or hydraulic oil temperatures ranging from -40°C and +100°C, unless otherwise stated.

- (d) the re-painting of the Products;
- (e) the transfer expenses of the Company's personnel during checking for flaws and defects reported by the purchaser.
- 2.6 Nothing will be due to the purchaser by way of compensation for the time that the machinery in which the defective Products are installed remain out of operation for the repair or replacement of the same, and the Company must be considered expressly released from liability for any direct or indirect damage, cost or expense derived by such machinery inactivity.
- 2.7 For the parts of the Product replaced or repaired, the guarantee will be automatically extended for a new 2-year period from the date of such replacement or repair.
- 2.8 Except in case of fraudulent intention or serious neglect, the Company will not be liable in any way for any direct or indirect damage, cost, loss, or expense to persons and/or property derived from the operation and use of the Products and/or the interruption of activity of the machinery in which the Products are installed, given that the guarantee specified in Article 2 is the only remedy in the purchaser's favour.
3. Guarantee exclusions
 - 3.1 The Company will not provide guarantee coverage for defects in conformity and/or flaws in the Product or any of its parts for any of the following cases:
 - (a) reasons due or linked to normal wear;
 - (b) the failure of the purchaser to correctly perform the procedures for the installation, use (or equivalent), and maintenance of the Products specified in the Use and Maintenance manual provided by the Company together with the Products;
 - (c) the incorrect use and/or operation of the Products or accident caused by the negligence, inexperience, or imprudence of the purchaser;
 - (d) the inadequate maintenance of the Products by the purchaser or modifications, repair and/or replacement made by the same without the Company's written consent;
 - (e) shock or impact against the vehicle or machinery in which the Products are installed; and
 - (f) causes other than defects in fabrication and/or engineering, working, and/or materials.
 - 3.2 Guarantee coverage will also be excluded whenever:
 - (a) the Company is not placed in the conditions to promptly perform the necessary repair or replacement of defective Products;
 - (b) the Products are modified by the purchaser;
 - (c) the Products are used after the discovery of a flaw or defect;
 - (d) Repairs that are not authorized by the Company are made;
 - (e) the flaw or defect regards paint coatings and/or is represented by the corrosion of parts of the Product coated or not coated.
4. Applicable Law - Controversy
 - 4.1 These General Guarantee Conditions are regulated by Italian Law with the express exclusion of the application of the United Nations Convention on international movable property sales contracts.
 - 4.2 Any controversy derived from these General Guarantee Conditions, including those regarding their validity, interpretation, execution and resolution that cannot be settled out of court will be subjected to the exclusive decision of the Court of Ravenna, Italy.

"General guarantee conditions" 19/11/2008



Dettagli Tecnici • Technical Data • Détail Techniques • Technischedatum • Detalles Tècnicos

H.S. Penta spa
via Proventa, 31
48018 Faenza RA - Italy
T +39 0546 689000
F +39 0546 664860
hspenta@hspenta.it
hspenta.it

A member of



**INTERPUMP
GROUP**